

# KOSTYRKA

---

## CLAMPING ELEMENTS FOR SLIDEWAYS

- Clamping Strips**
- Clamping Discs**
- Clamping Cassettes**
- Clamping Rings**



**Product Information**

## Basic information about "Clamping Elements for Slideways"

With over 30 years of experience, we are anxious to prove ourselves as competent partners for our customers, from the design and planning stage through final construction and implementation.

The following information is intended to clarify the connections in practical terms between clamping forces and clamping surfaces and thus help to ensure that our clamping systems for slideways are used as intended.

### Calculation of the necessary displacement resistance, the clamping force $F_K$

After pressure has been applied to the Clamping Strip or the Clamping Disc, normal force  $F_{NB}$  is present at pressure surface B, in the same way that counteracting force  $F_{GA}$  is present at the opposite face.

Due to the excessively high surface pressure which could arise on the friction surfaces of the Clamping Strips and Clamping Discs, and because of the tolerance of fits which would affect the exact positioning of the slide, the Clamping Strips and Clamping Discs must not be subjected to radial loading.

For this reason the normal force  $F_{NB}$  is not used to denote the clamping force  $F_K$ , but only the counteracting force  $F_{GA}$ , which is present at the opposite face A.

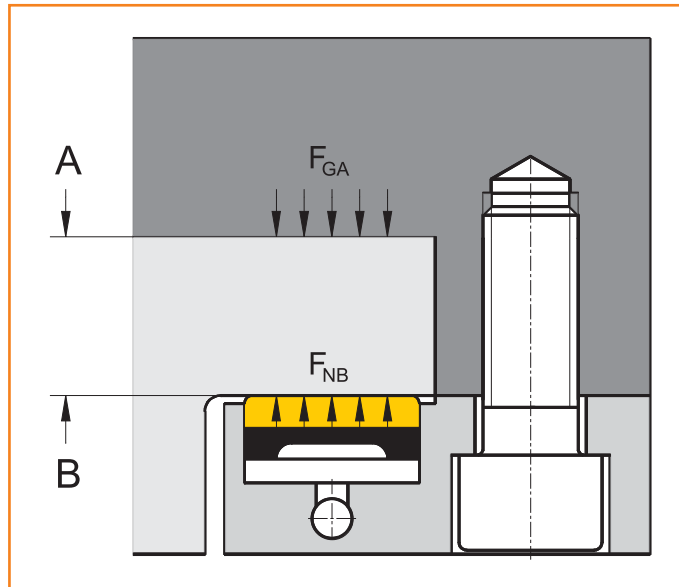

To find the clamping force  $F_K$ , which acts against the motion of the slide along the guide bed, the following formula is used:

$$F_K = F_{GA} \cdot \mu_A$$

$F_K$  = clamping force

$F_{GA}$  = counteracting force

$\mu_A$  = friction factor of the opposite faces

---

# Index

---

<b>1</b>	<b>Basics for KOSTYRKA® System of Clamping Elements for Slideways ...</b>	<b>3</b>
<hr/>		
<b>2</b>	<b>KOSTYRKA® Clamping Strips .....</b>	<b>4</b>
2.1	Method of Operation	
2.2	Materials	
2.3	General Tolerances	
2.4	Standard and Special Dimensions/ Clamping Forces	
2.5	Operating Conditions	
2.6	Fitting Regulations	
2.7	Anti-ejection Devices	
2.8	Examples of Mounting	
<hr/>		
<b>3</b>	<b>Clamping Discs .....</b>	<b>6</b>
3.1	Method of Operation	
3.2	Materials	
3.3	Operating Conditions	
3.4	Standard Dimensions / Clamping Forces	
3.5	Fitting Regulations	
3.6	Examples of Mounting	
3.7	Installation Tools	
3.7.1	Mounting Instructions	
<hr/>		
<b>4</b>	<b>KOSTYRKA® Clamping Cassettes .....</b>	<b>9</b>
<hr/>		
<b>5</b>	<b>KOSTYRKA® Clamping Rings .....</b>	<b>9</b>
5.1	Example of Mounting	

---

## 1 Basics for KOSTYRKA® System of Clamping Elements for Slideways.

The performance of modern machine tools places very high demands upon their individual elements. So, for example, the clamping elements used must be easy to handle, have a long life and be able to transmit considerable forces in the smallest of spaces.

KOSTYRKA® clamping elements for slideways not only fulfil these criteria, but in addition offer a range of additional advantages.

Standardised elements, ready for installation, made by KOSTYRKA®

- clamp slideways in mechanical engineering, such as bridges, pallets, slides, stands, supports, tailstocks, capstans...,
- exert no residual stress without releasing pressure,
- unusually compact design,
- exert very high clamping forces,
- react as quick as lightning, disconnect completely,
- require little maintenance and
- have proven themselves reliable for decades.

## 2 KOSTYRKA® Clamping Strips

### 2.1 Method of Operation

When the pressure is applied, the KOSTYRKA® Clamping Strip is forced out of its housing like a piston, contacts the component to be clamped and clamps it securely, as dictated by the amount of the oil pressure.

The O-ring, which is the seal component, is considerably compressed by this application of pressure. Once the oil pressure has completely released, the O-ring resumes its original shape. This relative movement causes the clamping strip to release itself from the clamped surface.

### 2.2 Materials

The Clamping Strip, with an O-ring/back-up ring combination, is usually made from brass. If required, the Clamping Strips can also be made from nitrided steel or case-hardened aluminium.

### 2.3 General Tolerances

All forms and sizes of KOSTYRKA® Clamping Strips are, in general, tolerated as follows: Length L  $-0.03/-0.06$  mm ( $-0.0012/-0.0023$  in.), width B  $-0.02/-0.04$  mm ( $-0.0008/-0.0016$  in.) and height H  $-0.1$  mm ( $-0.0040$  in.). Special tolerances are possible.



### 2.4 Standard and Special Dimensions/Clamping Forces

Since there is virtually no limit to the possible shapes these elements may take, we only hold a small selection of sizes in stock as standard. Those, which deviate from the standards, i.e., special dimensions, are manufactured according to the customer's specific requirements.

Please note that some of the standard dimensions listed below are also available in various special sizes and different heights with spring-loaded retraction, chamfered end ramps and anti-ejection devices, made from the above-mentioned materials.

The following table lists the standard dimensions produced and available at short notice. In order to ascertain the clamping forces a constant coefficient of friction value of  $\mu = 0.1$  was used for all operational pressures.

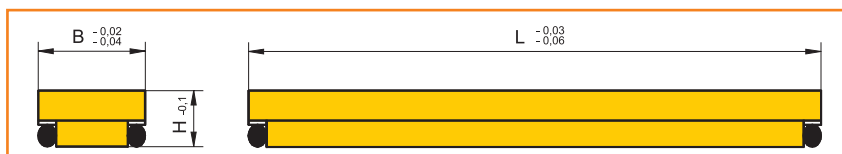

Type	Length L mm	Width B mm	Height H mm	Working area cm <sup>2</sup>	Working pressure bar (max.)	Working force kN	Clamping force kN
5800.74.00	60	8	7	4.66	450	20	2.0
5800.73.00	80	10	8.5	7.79	450	35	3.5
5820.20.22	100	20	12	19.14	450	86	8.6
5820.30.13	100	30	21	28.07	450	126	12.6
5800.36.00	104	12	13.5	12.17	450	55	5.5
5820.15.06	136	15	11	19.92	450	90	9.0
5820.30.22	150	30	21	43.07	450	193	19.3
5820.15.08	160	15	11	23.52	450	105	10.5
5820.35.02	190	35	18	63.87	450	287	28.7
5820.20.13	195	20	11	38.14	450	171	17.1
5820.15.03	200	15	11	29.52	450	132	13.2
5820.30.25	208	30	21	60.47	450	272	27.2
5820.20.15	230	20	11	45.14	450	203	20.3
5800.83.03	250	63	15	148.98	450	670	67.0
5800.77.02	385	70	15	258.98	450	1165	116.5

Subject to alteration

## 2.5 Operating Conditions

All types of KOSTYRKA® Clamping Strips are designed for operation with pressurized oil. It is, however, possible to control them with compressed air to transmit lower forces. If operating with compressed air care must be taken with regard to lubrication.

KOSTYRKA® Clamping Strips can be operated with all liquid media, to which the main casting and the O-ring/back-up ring combination are chemically and thermally resistant. These include hydraulic liquids and petroleum-based lubricants, transmission oils, animal and vegetable fats in the temperature range from -30 °C to +110 °C (-86 °F up to +235 °F).

Higher operating temperatures are made possible by VITON® O-rings, which can be supplied if required.

The maximum working pressure of KOSTYRKA® Clamping Strips is 450 bar (6,500 psi.).

## 2.6 Fitting Regulations

The housings for KOSTYRKA® Clamping Strips can be manufactured without difficulty using track-controlled milling machines, during which process the surface roughness of the walls of the housing may not exceed  $R_{max} = 6-10 \mu\text{m}$  (microns) ( $R_a \leq 1.6 \mu\text{m}$ ).

The length  $L$  and width  $B$  of the housing each has a tolerance of  $+0.02/0.06 \text{ mm}$  ( $+0.0008/+0.0025 \text{ in.}$ ); the depth of the housing should be 2 mm (0.080 in.) greater than the height  $H$  of the Clamping Strip.

In order to avoid the O-ring being cut or damaged during installation, it is imperative to use an all-round 20° lead-in chamfer of a suitable size.

To vent the Clamping Strip system, provision should be made for a venting hole near the oil port.

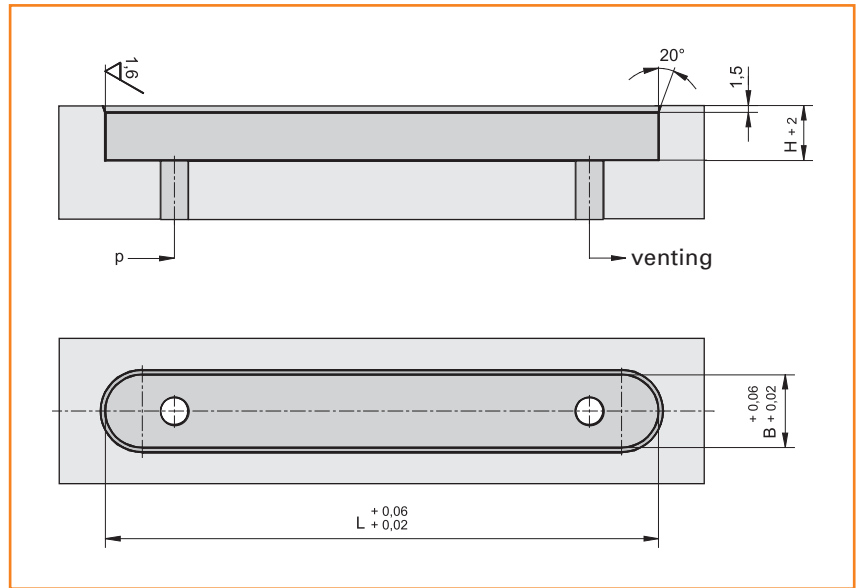

Housings for KOSTYRKA® Clamping Strips

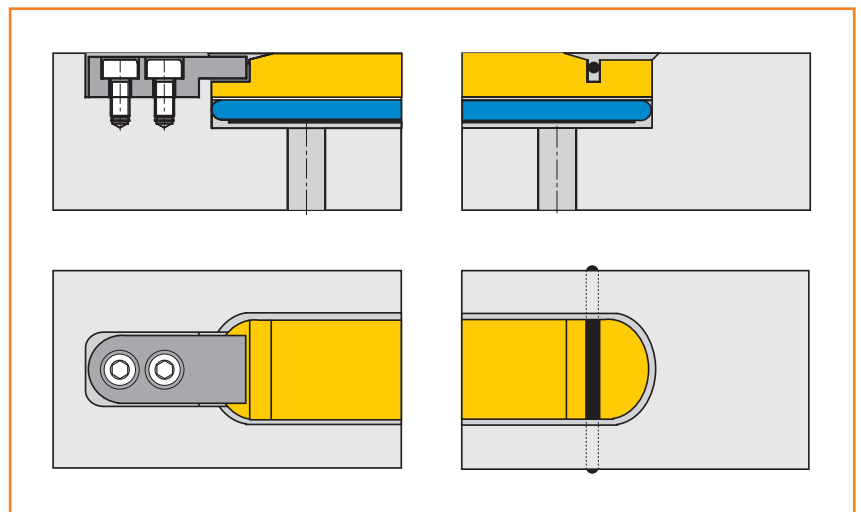

Anti-ejection mounting bracket device

Anti-ejection pin device

## 2.7 Anti-ejection Devices

Two types of anti-ejection devices are shown here.

On the left a mounting bracket restrains the Clamping Strip, on the right this task is undertaken by a pin. The purpose of the anti-ejection

device is to keep the Clamping Strip in its housing even without a counterpart in place. Naturally this occurs only at reduced operating pressure.

### Note:

The safety devices shown, like the spring returns, can never absorb the working force of a Clamping Strip at full operating pressure.

## 2.8 Examples of Mounting

**Figure 1**

Shows the classical use of KOSTYRKA® Clamping Strips. Here the Clamping Strips are mounted in a Clamping Cassette. For further information about these see also section 4 "KOSTYRKA® Clamping Cassettes"

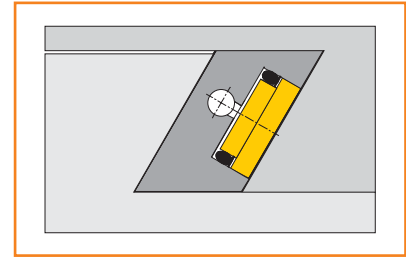
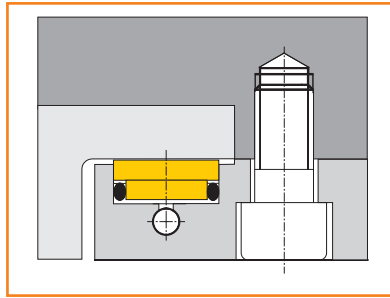

**Figure 2**

KOSTYRKA® Clamping Strips can be installed directly into a V-ledge design



**Figure 3**

KOSTYRKA® Clamping Strip systems are particularly easy to vent, since oil feed holes or vent

holes are provided on each side of the clamping component.

## 3 Clamping Discs

### 3.1 Method of Operation

When pressure is applied, the KOSTYRKA® Clamping Discs are forced out of their housing like a piston, place themselves onto the component to be clamped and clamp it firmly, as determined by the amount of the oil pressure. After the oil pressure has completely released, the Clamping Discs "spring" back approximately 0.01 mm (0.0004 in.), without the seal moving in the location hole. This feature eliminates wear and tear on the seals and assures long and trouble-free operation.

### 3.2 Materials

The Clamping Discs are made from bronze and have a vulcanised high-pressure seal of Perbunan.



### 3.3 Operating Conditions

Clamping Discs can be operated by any liquid media against which the high-pressure seal is chemically and thermally resistant. These include inflammable, mineral-oil-based working substances, animal and vegetable oils and fat, aliphatic hydrocarbons (propane, butane, benzene), silicon oils and fat, water up to +80 °C (+180 °F), bio-oils made

from synthetic esters and vegetable oils in the -30 °C to +110 °C (-86 °F up to 230 °F) temperature range.

The maximum working pressure for standard Clamping Discs amounts to 250 bar (3,625 psi.).

If required, higher working pressures can be achieved using special high-pressure seals, which are available. Please inquiry if interested.

### 3.4 Standard Dimensions/Clamping Forces

The following table lists the standard dimensions produced and available at short notice.

In order to ascertain the clamping forces a constant coefficient of friction value of  $\mu = 0.1$  was used for all operational pressures.

Type	Unit height H mm	Diameter D mm	Working area cm <sup>2</sup>	Working pressure bar (max.)	Working force kN	Clamping force kN (max.)
5650.16	8	16	2.01	250	5	0.5
5650.22	8	22	3.80	250	9	0.9
5650.28	8	28	6.16	250	15	1.5
5650.32	8	32	8.04	250	20	2.0
5650.42	8	42	13.85	250	34	3.4
5650.52	8	52	21.23	250	53	5.3
5650.64	8	64	32.16	250	80	8.0

Subject to alteration

### 3.5 Fitting Regulations

For all sizes of Clamping Discs in an unmounted state the unit height H amounts to 8 mm (0.315 in.). Since the high-pressure seal is considerably compressed during mounting, the height increases to a maximum value of 9 mm (0.354 in.).

Therefore the depth of the location hole for all clamping disc dimensions must be a minimum of 10 mm (0.393 in.).

The surface roughness of the location hole may not exceed  $R_{max} = 6-10 \mu\text{m}$  (microns) ( $Ra \leq 1.6 \mu\text{m}$ ). It is imperative that machining grooves, particularly longitudinal grooves in the jacket surface are avoided!

The diameter of the location hole is to be of DIN ISO tolerance H7 fitting. If several Clamping Discs are connected by a single longitudinal hole, a vent hole should be provided.

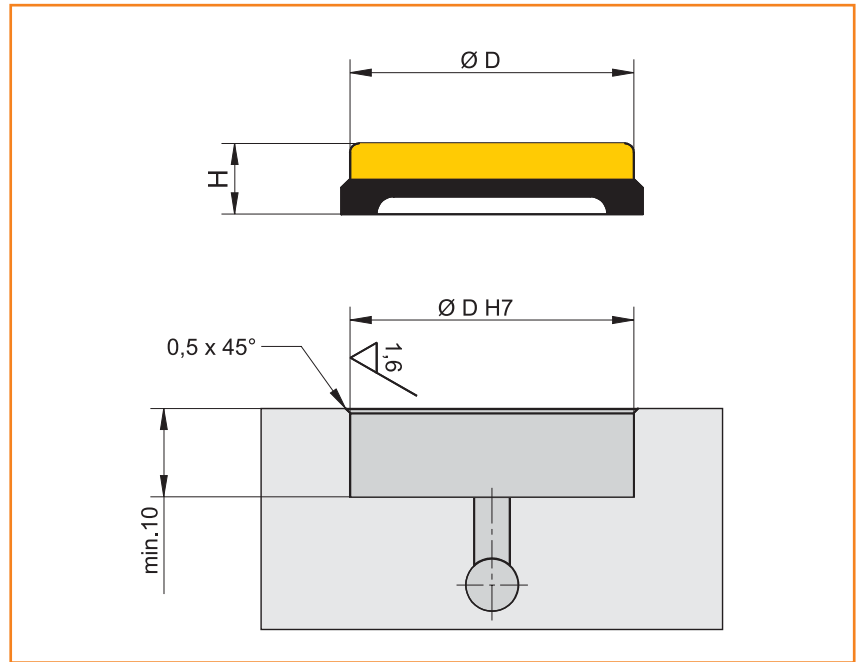

### 3.6 Examples of Mounting

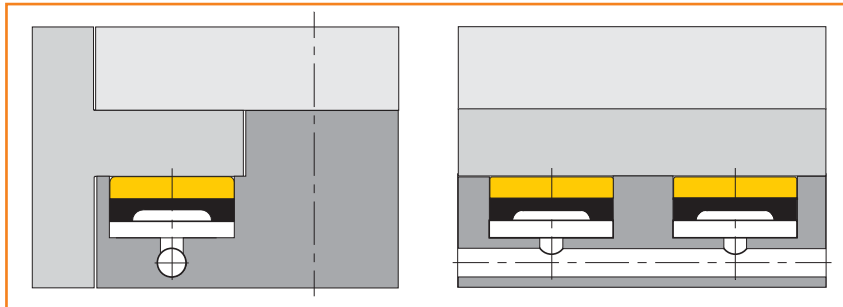

**Figure 1** shows the classical method of using Clamping Discs. These are set into a lower locking bar and joined together by means of a continuous longitudinal hole.

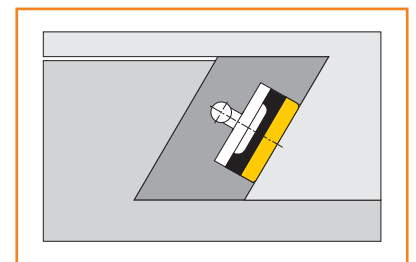

**Figure 2** Clamping Discs can be installed directly into a V-ledge design.



## 4 KOSTYRKA® Clamping Cassettes

Unfavourable space conditions can have the result of making the direct mounting of the necessary tensioning or clamping elements difficult, if not impossible.

With KOSTYRKA® Clamping Cassettes – in which the power-transmitting Clamping Strips are already integrated – an additional attachment is made possible. Especially with KOSTYRKA® Clamping Cassettes the retrofitting of old machine tools onto modern, more effective clamping elements is made significantly easier.

Since the form of KOSTYRKA® Clamping Cassettes is exclusively directed towards customer-specific requirements and situations, it is not possible to stock standard units.

Please make an inquiry if interested.

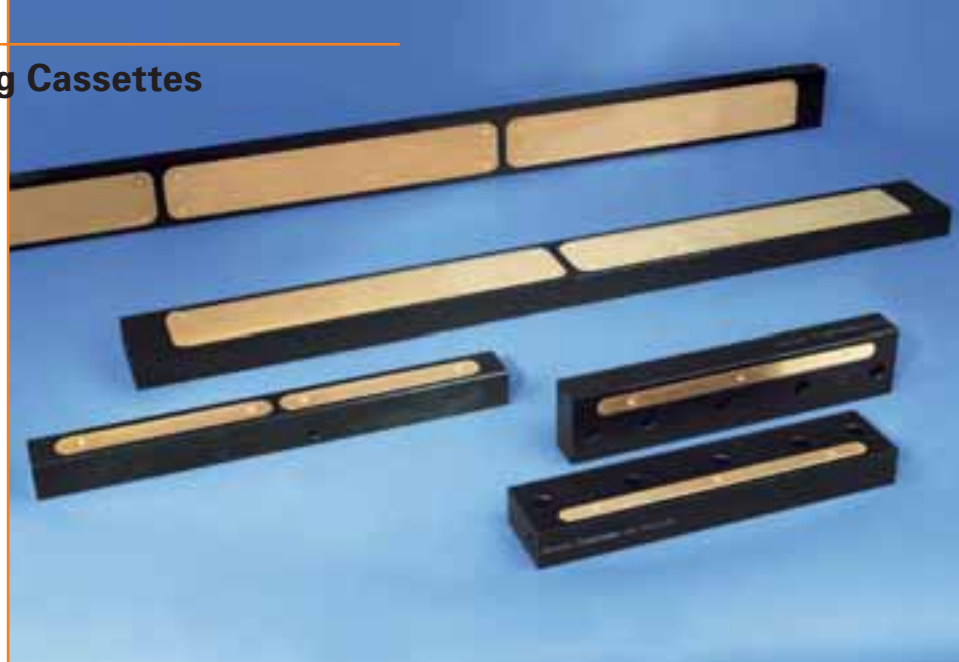

## 5 KOSTYRKA® Clamping Rings

The multiple tried and tested new KOSTYRKA® Clamping Rings represent highly efficient and extremely compact constructional clamping elements. They are used for clamping in general mechanical engineering as well as for parts of couplings and brakes.

Function: The ring, made from bronze with particularly good elastic properties and skilful profiling, is expanded by oil pressure and returned to its original position when the pressure is released.

Since the form of KOSTYRKA® Clamping Rings is exclusively directed towards customer-specific requirements and situations, here, too, it is not possible to stock standard units.

Please make an inquiry.

### 5.1 Example of the installation of KOSTYRKA® Clamping Rings

The example shows the clamping of a fork type milling head with a controlled shaft by two KOSTYRKA® Clamping Rings.

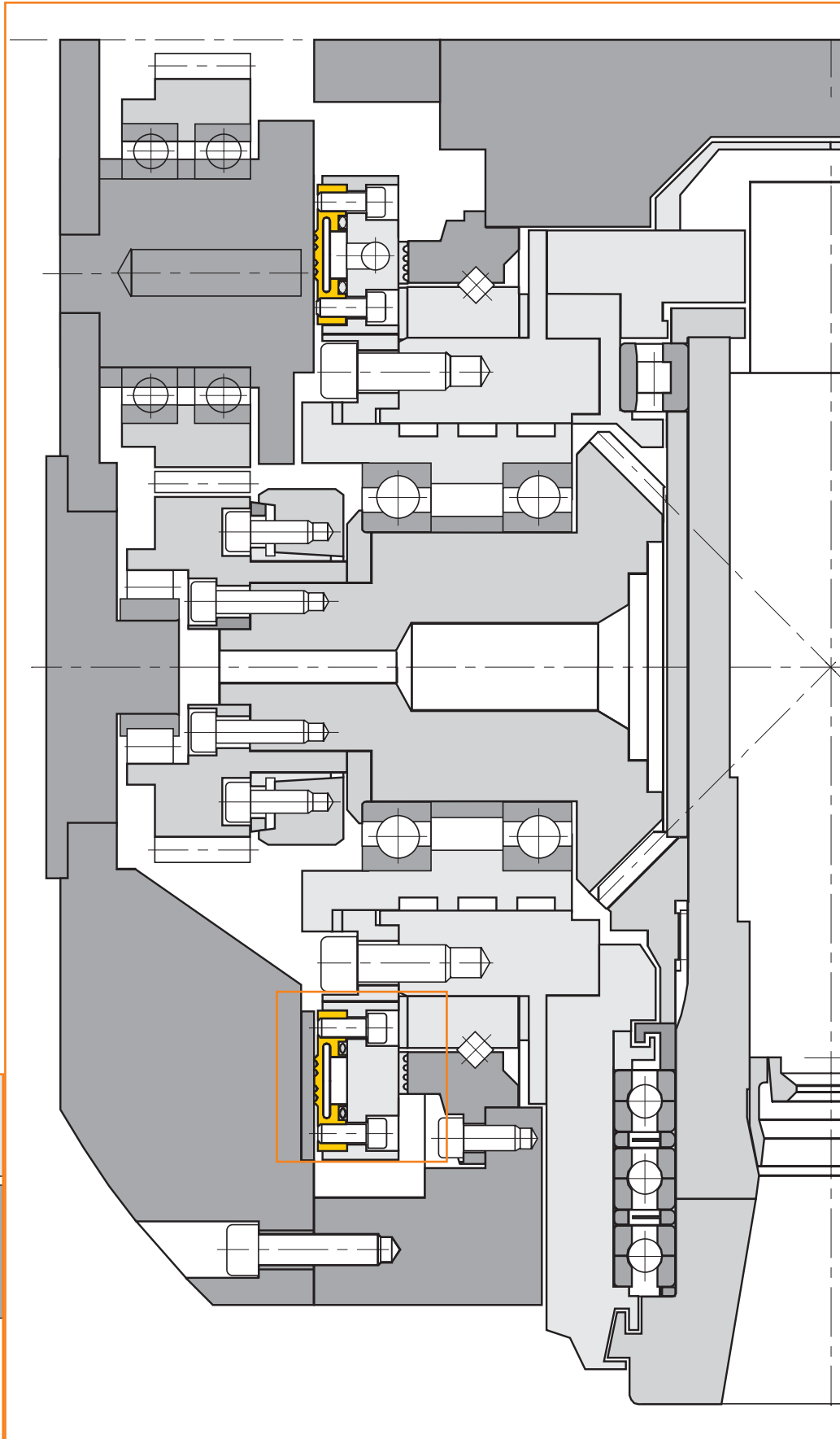
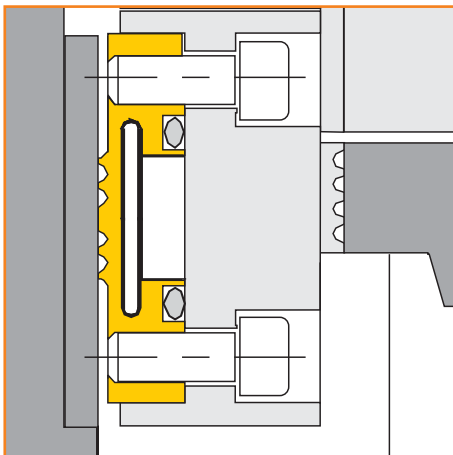

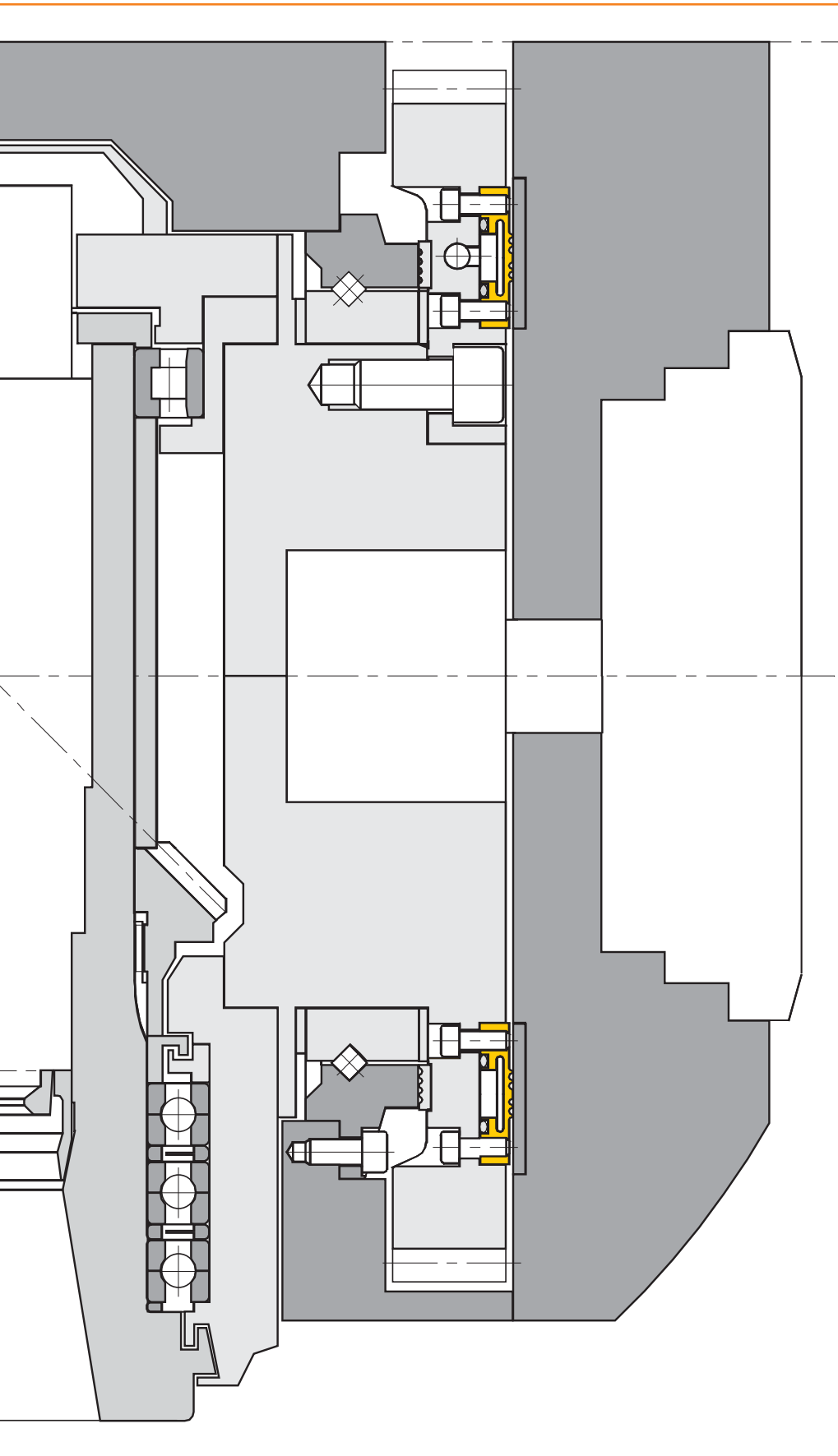

---

## We are available for you

### **KOSTYRKA GmbH**

Motorstraße 41 · D-70499 Stuttgart  
P.O.B. 311404 · 70474 Stuttgart  
Germany

Phone +49 (0) 711/88710-0  
Fax +49 (0) 711/88710-30

info@kostyrka.com  
www.kostyrka.com

